

TM 9-4910-719-14&P

---

TECHNICAL MANUAL

OPERATOR'S ORGANIZATIONAL, DIRECT SUPPORT  
AND GENERAL SUPPORT MAINTENANCE MANUAL  
INCLUDING REPAIR PARTS LIST

BEAD BREAKER, PNEUMATIC  
MODEL IMT 200HP  
(IOWA MOLD TOOLING CO., INC.)  
(NSN 4910-01-015-7667)

---

HEADQUARTERS, DEPARTMENT OF THE ARMY  
JANUARY 1982

#### W A R N I N G

The air/hydraulic pump is capable of generating fluid pressure up to 10,000 PSI. Keep both hands on the handles and away from the clamping jaw or breaker tongue. Make certain that the tool is properly aligned on the rim before allowing the bead breaking action. Do not continue to operate the air/hydraulic pump once the breaker rod is completely extended. Failure to comply with these instructions could result in personal injury or damage to the equipment.

TECHNICAL MANUAL }  
No. 9-4910-719-14&P }

HEADQUARTERS  
DEPARTMENT OF THE ARMY  
WASHINGTON, DC, 25 January 1982

OPERATORS, ORGANIZATIONAL, DIRECT SUPPORT  
AND GENERAL SUPPORT MAINTENANCE MANUAL  
INCLUDING REPAIR PARTS LIST

**BEAD BREAKER, PNEUMATIC  
MODEL IMT 200HP  
(NSN 4910-01-015-7667)**

**REPORTING ERRORS AND RECOMMENDING IMPROVEMENTS**

You can help improve this manual. If you find any mistakes or if you know of a way to improve the procedures, please let us know. Mail your letter, DA Form 2028 (Recommended changes to Publications and Blank Forms), or DA Form 2028-2, located in the back of this manual direct to: Commander, US Army Armament Materiel Readiness Command, ATTN: DRSAR-MAS, Rock Island, IL 61299. A reply will be furnished direct to you.

**NOTE**

This manual is published for the purpose of identifying an authorized commercial manual for the use of the personnel to whom this bead breaker is issued.

Manufactured by: Iowa Mold Tooling Co., Inc.  
500 Highway 18 West  
Garner, IA 50438

Procured under Contract No. DAAA09-79-F-6125

This technical manual is an authentication of the manufacturers' commercial literature and does not conform with the format and content specified in AR 310-3, Military Publications. This technical manual does, however, contain available information that is essential to the operation and maintenance of the equipment.

**INSTRUCTIONS FOR REQUISITIONING PARTS  
NOT IDENTIFIED BY NSN**

When requisitioning parts not identified by National Stock Number, it is mandatory that the following information be furnished the supply officer.

- 1 - Manufacturer's Federal Supply Code Number-54209
- 2 - Manufacturer's Part Number exactly as listed herein.
- 3 - Nomenclature exactly as listed herein, including dimensions, if necessary.
- 4 - Manufacturer's
- 5 - Manufacturer's Serial Number (End Item)
- 6 - Any other information such as Type, Frame Number, and Electrical Characteristics, if applicable.
- 7 - If DD Form 1348 is used, fill in all blocks except 4, 5, 6, and Remarks field in accordance with AR 725-50.

Complete Form as Follows:

(a) In blocks 4,5,6, list manufacturer's Federal Supply Code Number-54209 followed by a colon and manufacturer's Part Number for the repair part.

(b) Complete Remarks field as follows:

Noun: (nomenclature of repair part)

For: NSN: 4910-01-015-7667

Manufacturer: Iowa Mold Tooling Co., Inc.

500 Highway 18 West

Garner, IA 50438

Model: IMT 200HP

Serial: (of end item)

Any other pertinent information such as Frame Number, Type, Dimensions, etc.

**TABLE OF CONTENTS**

<b>Paragraph</b>	<b>Title</b>	<b>Page</b>
<b>SECTION 1. GENERAL</b>		
1-1.	INTRODUCTION . . . . .	1
<b>SECTION 2. OPERATION</b>		
2-1.	OPERATION . . . . .	1
<b>SECTION 3. SERVICE</b>		
3-1.	INTRODUCTION . . . . .	3
3-2.	DISASSEMBLY . . . . .	3
	3-2-1. Bead Breaker . . . . .	3
	3-2-1-1. Clamping Cylinder . . . . .	3
	3-2-1-2. Breaker Cylinder . . . . .	5
	3-2-1-3. Bead Breaker Purging . . . . .	6
	3-2-2. Air/Hydraulic Pump . . . . .	7
3-3.	CLEANING . . . . .	8
3-4.	STORAGE . . . . .	8
3-5.	TROUBLESHOOTING . . . . .	8
<b>SECTION 4. PARTS</b>		
4-1.	INTRODUCTION . . . . .	9
4-2.	CONVERSION KITS . . . . .	10
4-3.	INTERMEDIATE SERIES B. . . . .	10
<b>SECTION 5. OIL SPECIFICATIONS</b>		
5-1.	OIL SELECTION . . . . .	14

**LIST OF ILLUSTRATIONS**

<b>Figure</b>	<b>Title</b>	<b>Page</b>
1	Sequence of Operation . . . . .	2
2	Bead Breaker . . . . .	4
3	U Cup Installation . . . . .	5
4	Jaw Conversion . . . . .	10
5	Bead Breaker Parts Drawing . . . . .	11
6	Air/Hydraulic Pump Parts Drawing . . . . .	12

**LIST OF TABLES**

<b>Table</b>	<b>Title</b>	<b>Page</b>
1.	Troubleshooting Chart . . . . .	8
2.	Revision . . . . .	9
3.	Internal Conversion Kit . . . . .	9
4.	Jaw Conversion Kit . . . . .	10
5.	Hydraulic Oil Specifications . . . . .	14

LIST OF TABLES

Table	Title	Page
1.	Troubleshooting Chart . . . . .	8
2.	Revisions . . . . .	9
3.	Internal Conversion Kit . . . . .	9
4.	Jaw Conversion Kit. . . . .	10

# IMT 200HP Bead Breaker (Series B)

(part number 92900140) Consisting of the following:  
Bead Breaker Tool (part number 79075030)  
Air/Hydraulic Pump (part number 73051010)

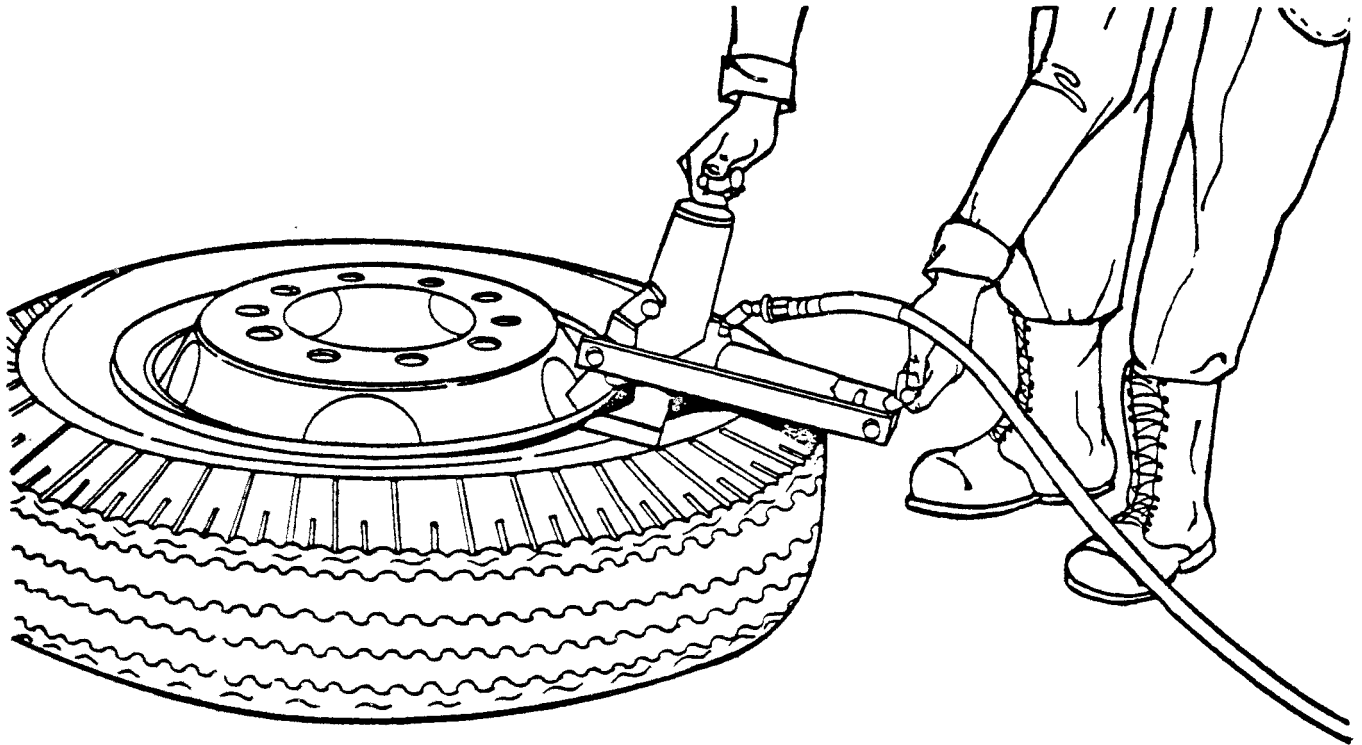





# Section 1 General

## 1-1. INTRODUCTION

The IMT 200 HP Bead Breaker System consists of the Bead Breaker Tool and the Air/Hydraulic Pump.

The air/hydraulic pump consists of an inline air and hydraulic cylinder. The ratio of hydraulic fluid pressure generated compared to supply air pressure is 100:1. In other words, 100 PSI out for every 1 PSI in - 100 PSI input air pressure equals 10,000 PSI output pressure.

The bead breaker tool consists of two cylinders - a clamping cylinder and a breaker cylinder at a 90° angle with respect to each other. Both the clamping and bead breaking actions are performed automatically - no mid-sequence operation by the user.

The sequence of operation is as follows (refer to Figure 1).

In Step 1, the air/hydraulic pump supplies the hydraulic fluid pressure to the clamping cylinder. Fluid pressure is restricted to the clamping cylinder by spring pressure on the sequence ball and by the mated surfaces of the fluid return ball and its seat. As the clamping rod moves out of the cylinder, the jaw clamps firmly on the rim.

In Step 2, the internal hydraulic pressure of the clamping cylinder is sufficient to overcome the spring pressure against the sequence ball (approximately 2,500 PSI). The ball is forced away from the seat and pressure increases inside the breaker cylinder.

The breaker rod has moved out of the cylinder and the tongue is pressing against the bead in Step 3. As pressure increases, the tongue will break the bead of the tire from the rim.

Depressing the release pedal causes a decrease in pressure in the clamping cylinder. With less pressure on the clamping cylinder side of the fluid return ball than on the breaker side, the fluid return ball is lifted off the seat and the breaker rod retracts in Step 4. Retraction is due to an internal spring and pressure of the bead against the tongue. The breaker rod retracts first, followed by the clamping rod.

### WARNING

The air/hydraulic pump is capable of generating fluid pressure up to 10,000 PSI. Keep both hands on the handles and away from the clamping jaw or breaker tongue. Make certain that the tool is properly aligned on the rim before allowing the bead breaking action. Do not continue to operate the air/hydraulic pump once the breaker rod is completely extended. Failure to comply with these instructions could result in personal injury or damage to the equipment.

# Section 2 Operation

## 2-1. OPERATION

Operation of the unit is as follows:

Make certain that the tire is completely deflated.

Connect the hose of the air/hydraulic pump to the hydraulic coupling on the tool. Connect the air supply line to the air/hydraulic pump. Air supply should be 5-10 CFM at 100 PSI to obtain proper operating characteristics. In addition, the air line should be equipped with an air line filter.

Position the bead breaker so that the cup point set screw in the jaw makes solid contact with the rim and the teeth are positioned in the crevice between the bead of the tire and the rim.

### NOTE

When a tire has a trash guard, you may have to drive two straight tire irons between the rim and the tire bead to get a starting point for the teeth.

Step on the PUMP end of the pedal. The clamping rod will begin to extend and the jaw will grip the rim.

### CAUTION

Make certain that the teeth are slipping in between the rim and the bead. If not, depress the RELEASE end of the pump pedal and realign the tool. If the tool is not positioned correctly, extending the breaker rod may damage the tool.

Continue pumping until the tongue of the breaker pushes the bead free of the rim.

Depress the RELEASE end of the pump pedal.

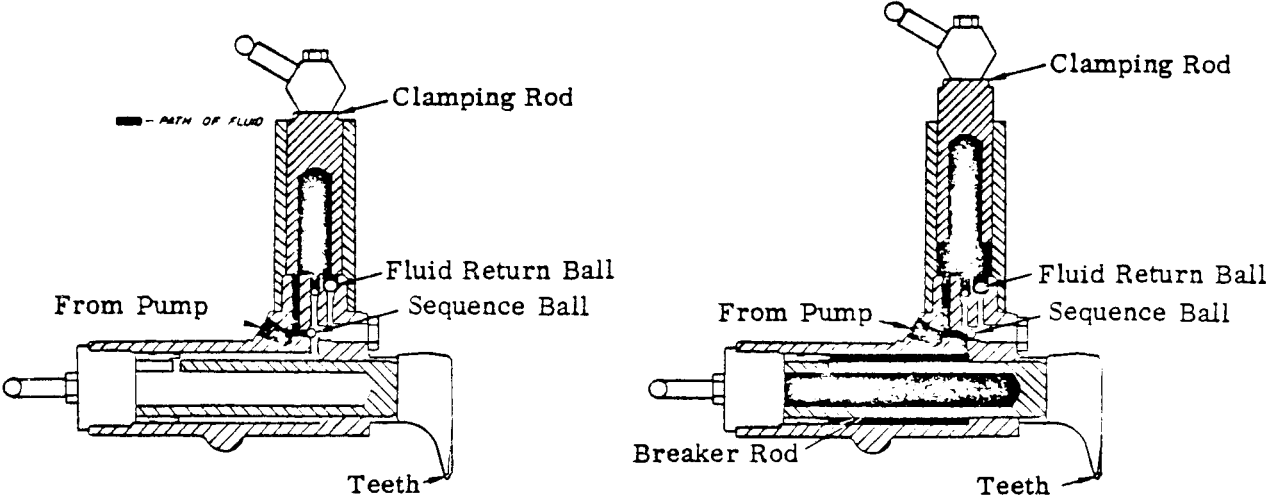

**Step 1**

**Step 2**

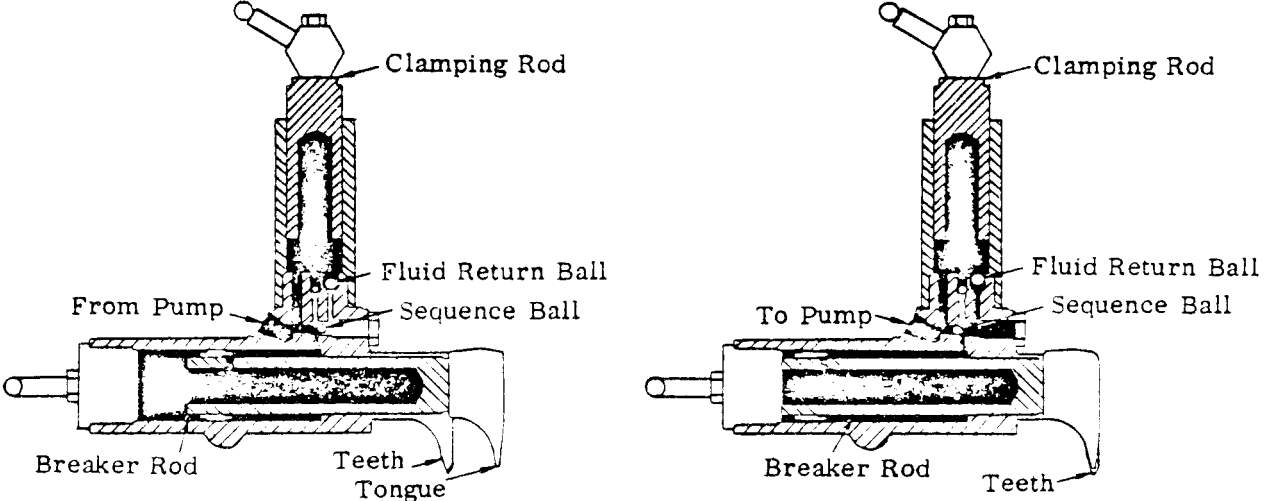

**Step 3**

**Step 4**

**Figure 1. Sequence of Operation**

## Section 3

### Service

#### 3-1. INTRODUCTION

Most malfunctions are a direct result of foreign matter - dirt, dust, water - entering the tool through the open hydraulic coupler union. Keep the union clean and capped when the pump is not connected to the tool. If the air/hydraulic pump is to be used only with the bead breaker, it is recommended that the pump be permanently attached to the tool. This is accomplished by removing the quick-disconnect coupler union, the 45° elbow and the nipple, inserting a swivel and attaching the hose from the pump directly to the swivel. Use a pipe thread compound when assembling. This will eliminate the possibility of contamination through the open coupling.

The bead breaker and pump are relatively easy to service. Some tools will be required for disassembly and assembly. These are:

1. Spanner wrench
2. Common Screwdriver
3. Needle nosed pliers
4. Ice pick or sharp awl
5. Allen wrenches
6. Open end wrenches
7. Retaining ring pliers
8. Socket wrenches
9. Ratchet
10. Torque wrench

#### 3-2. DISASSEMBLY

These instructions deal with the complete disassembly of the bead breaker and pump.

##### 3-2-1. Bead Breaker

Before disassembling the bead breaker, the outside must be thoroughly cleaned to prevent contaminating the interior. Use warm, soapy water, rinse with clear water and wipe or blow the tool dry.

#### CAUTION

Proceed with disassembly in a warm, clean environment - one that is free of dust, dirt, grease, solvents, and has a temperature of at least 70° F.

##### 3-2-1-1. Clamping Cylinder

To disassemble the clamping cylinder, proceed as follows (refer to Figure 2):

Remove the four E retaining rings that secure the clamping arms. Remove the arms.

Unscrew the bolt at the top of the cylinder and remove the handle block.

Probe in the hole at the top of the clamping rod with a 5/32" Allen wrench (long leg in the hole). Unscrew and remove the socket head screw and washer.

Reinstall the bolt and handle block removed in a previous step. Pull the rod out of the cylinder using the handle block.

Unscrew the cylinder with a spanner wrench. Work the o-ring and back-up washer over the threaded portion of the body casting and remove them.

Grip the lip of the wiper with the needle nosed pliers and pull the wiper from the groove in the cylinder.

Puncture the u cup with an ice pick or sharp awl. Pry it out of the groove and push it on through the cylinder.

If it is necessary to remove the spring, grip it and turn it counterclockwise.

This completes cylinder disassembly.

To assemble the clamping cylinder, proceed as follows:

#### NOTE

Use all of the seals supplied in the seal kit. It may avoid costly repairs in the near future.

Thread the bottom spring anchor on the slotted headless screw and rotate the spring clockwise until it is tight.

Install the back-up washer and o ring over the threaded portion of the body casting.

#### CAUTION

Work the o-ring and back-up washer slowly into position. Avoid stretching them excessively.



Position the cylinder with the wiper pocket up. Grasp the u cup with the needle nosed pliers (Figure 3) and insert it into the cylinder. Allow it to snap into place, helping with the fingers if necessary.

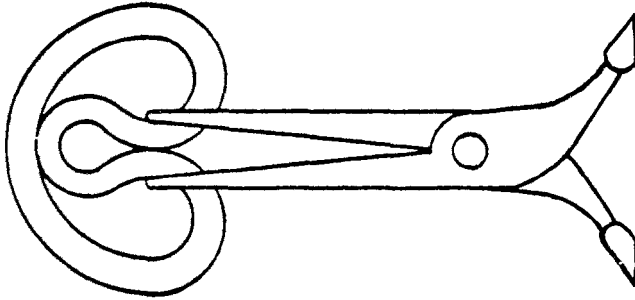

Figure 3. U Cup Installation

Install the wiper.

Lubricate the threads on the cylinder and the body with lubricating oil (9150-00-942-0493). Screw the cylinder onto the body casting by hand. Get it as tight as possible. Torque the cylinder to 125-175 ft. lbs.

Slide the rod carefully through the wiper and u cup and over the spring until it bottoms out. Insert the washer and socket head screw into the hole in the top of the rod. With a 5/32" Allen wrench, turn the socket head set screw clockwise into the spring anchor. Torque at 90-110 in. lbs.

Position the handle block over the hole at the top of the rod and secure it with the bolt. Do not tighten the bolt.

Slide the clamping arms over the jaw pin and handle block pin and secure them with the four E retaining rings.

Tighten the bolt through the handle block (30-40 ft. lbs).

Install the sequence ball, spring, washer and cap. Torque to 35-40 ft. lbs.

Purge the system of air (refer to paragraph 3-2-1-3).

This completes cylinder assembly.

### 3-2-1-2. Breaker Cylinder

Refer to Figure 2 for location of parts. The cylinder is disassembled as follows:

Loosen the jam nut on the T handle and remove the handle.

Probe inside the hole in the head with 5/32" Allen wrench and remove the socket head screw and washer.

Remove the head with a spanner wrench.

Grip the tongue and pull it forward. Drive out the spring pin securing the tongue to the rod and slide the tongue off the rod.

Push the rod back into the cylinder and pull it out the other end.

#### CAUTION

Do not attempt to remove the retaining rings or bearing from the rod. Special tools are required for this operation. Return the entire tool to the nearest service center.

Probe in the tongue end of the rod with a 5/32" Allen wrench and remove the socket head screw and washer.

Position the tool with the teeth up. Grip the lip of the wiper with the needle nosed pliers, and pull it out of the groove.

Puncture the u cup with an ice pick or sharp awl. Pry the u-cup from the groove and push it on through the cylinder.

Work the o ring and back-up washer off the head.

Breaker cylinder disassembly is now complete.

Cylinder assembly is accomplished as follows:

#### NOTE

Use all of the seals supplied with the seal kit. It may avoid costly repairs in the near future.

Hold the spring inside the rod. Insert the socket head screw and washer into the hole in the tongue end of the rod and torque to 90-110 in. lbs.

Position the cylinder with the teeth up. Grip the u cup with the needle nosed pliers (Figure 3) and insert it into the cylinder. Allow it to snap into place helping with the fingers if necessary.

Install the wiper.

Insert the rod assembly from the head end of the cylinder and slide it through the u cup and wiper.

Slip the tongue onto the rod and fasten it in place with the spring pin.

Work the back-up washer and o ring onto the head.

**CAUTION**

Work them slowly into position. Avoid stretching them excessively.

Lubricate the head and cylinder threads with lubricating oil (9150-00-942-0493). Screw the head into the cylinder and torque to 175-225 ft. lbs.

Install the socket head screw and washer (torque to 90-110 in. lbs).

Thread the T handle into the head until it bottoms out. Tighten the lock nut.

Purge the tool of air (refer to paragraph 3-2-1 -3).

Assembly of the breaker cylinder is complete.

**3-2-1-3. Bead Breaker Purging**

Purging is accomplished as follows:

Connect the air/hydraulic pump to the tool.

Connect the pump to the air supply.

Position the pump so that it is higher than the tool and depress the PUMP end of the pedal.

After the clamping and breaker rods are fully extended, depress the RELEASE end of the pedal. Repeat this cycle (PUMP-RELEASE) about five times.

Extend both rods and keep them extended. Check for leaks. Make certain that the rods do not creep back into the cylinders.

**3-2-2. Air/Hydraulic Pump**

Before disassembling the pump, the outside must be thoroughly washed to prevent contaminating the interior. Before washing, remove the pedal (item 67, Figure 6) by removing one of the E retaining rings and sliding the pin (item 64) out of the hole. Lift off the pedal - the wavy washers (item 56) will fall out. Wash thoroughly with warm, soapy water, rinse with clean water and wipe or blow the pump dry.

**CAUTION**

Proceed with disassembly in a clean, warm environment - one that is free of dust, dirt, and has a temperature of 70° F. or warmer.

To disassemble, proceed as follows (refer to Figure 6 for item numbers):

Remove the six self-tapping screws (item 69) and lift off the cover/pump assembly. Set the reservoir (item 57) and gasket (item 55) to one side.

Remove the six socket head screws (item 61) and lift off the muffler (items 42 and 72), the intake air valve body (item 68), the release valve body (item 66) and the cover (item 63).

The air valve may be further disassembled by removing the socket head screw (item 36), drawing items 39 and 40 out of the top and items 36 and 38 out of the bottom.

The release valve may be further disassembled by drawing items 1, 44, 45 and 47 out of the bottom. The seal (item 58) was pressed into place and must be pressed out to remove.

The pump assembly (under the cover) may also be disassembled.

Lift out the springs (items 5, 34 and 46) and ball (item 6).

Clamp the rear head (item 27) in a vise. Remove the four socket head screws (item 70) and washers (item 71).

**NOTE**

It is easier to remove three socket head screws (item 70) completely and then, using hand pressure to hold the pump body in place, remove the fourth screw. Spring tension (item 20) will cause the pump body (item 8) to lift away from the cylinder (item 60).

Carefully lift off the pump body (item 8), the hydraulic piston, spring guide and spring (items 13, 20 and 21).

Lift the cylinder (item 60) off the rear head. Push the air piston out of the cylinder.

Remove the three socket head screws and washers (items 28 and 29) from the air piston assembly. Remove all parts. The piston poppet (item 31) can be pulled off the end of the exhaust valve stem (item 32).

Remove the piston rings and back-up rings (items 25 and 33) with a small, common screwdriver.

Place the pump body (item 8) in a vise with the cylinder end facing up. Remove the internal retaining ring (item 18) with retaining ring pliers. Lift out the retainer nut (item 17). Packing u cup nylon (item 19) will have to be pressed out from the other end of the pump body. Remove the cylinder (item 15) with a 1" socket

Reposition the pump body in the vise so that the filter (item 12) is on top. Remove the filter, adapter, copper washer and ball (items 9, 10, 11 and 12).

Insert a common screwdriver in the slot at the top of the poppet retainer (item 48). Rotate it back and forth to loosen it. Grip the retainer and pull it out of the pump body.

**NOTE**

Socket head screw and washer (item 3 and 4) are used as a plug. There is no need to remove them. Relief valve (item 7) is factory preset at 10,000 PSI. There should be no need for its removal. If it is defective, replace the entire relief valve assembly. The new assembly is also preset. Do not disassemble before installation or the setting will be incorrect.

Disassembly is complete.

The pump is assembled as follows:

**NOTE**

Use all of the components supplied with the seal kit.

Insert the release valve components (items 48, 49, 50, 51, 52, 53 and 54) into the pump body (item 8).

Position the pump body in a vise with the filter port up. Install the filter, adapter, copper washer and ball (items 9, 10, 11 and 12).

Reposition the pump body with the cylinder end up. Install the cylinder, u cup, retainer nut, retaining ring and washer, copper (items 14, 15, 17, 18 and 19).

Clamp the rear head (item 27) in a vise and insert the back-up ring (item 59).

Assemble the piston (Items 22, 23, 24, 25, 26, 28, 29, 30, 31, 32, and 33). Apply staking compound (8040-00-225-1 959) to the threads of the socket head screws (Item 29) and torque them to 50-55 In. lbs.

Lubricate the piston rings and the inside of the air cylinder with oil. Insert the piston into the air cylinder (item 60) and squirt more oil around the circumference of the piston. Work the piston back and forth to distribute the oil.

Position the cylinder/ piston group on the rear head with the groove on the rear head with the groove on the inside of the cylinder toward the top of the rear head.

Position the gasket (item 16) on the pump body. A little oil will help hold the gasket in place.

Position the spring guide, hydraulic piston and spring (Items 13, 20, and 21) over the air piston. Align the pump body so the hydraulic piston slides through the retainer nut (Item 17).

Push the pump body down against the cylinder. Install the four socket head screws and washers (Items 70 and 71) and torque them to 90-100 In. lbs.

**NOTE**

The easiest way to assemble the rear head, cylinder and pump body is to start one screw and get it finger tight. That will take up the spring tension and make it easier to install the others.

Position the pump assembly in the vise with the top up. Place new gaskets on the pump body and rear head. Oil will help hold them in position.

Place the cover on top of the gaskets and insert the o rings (item 35 - 2 required and item 2).

With your fingers, press items 1, 44, 45, and 47 into the ports in the release valve body. Place the ball (item 6) and springs (items 5 and 46) into the ports of the pump body. Install item 58 (must be pressed into place).

Align the release valve body on the cover and start the four socket head screws. Do not tighten the screws.

Install item 36, 37, 38, and 40 in the air valve body. Place the spring (item 34) in the port in the rear head.

Position the muffler (items 42 and 72) between the valve bodies and secure the valve bodies in place (torque the screws to 25-30 in. lbs.).

Position the pedal and slide a wavy washer between the pedal and release valve body. Slide the pin partially through the body and insert a wavy washer on the other side of the release valve body. Slide the pin all the way through the valve body, washer and pedal and secure it with the other E retaining ring.

Position the assembled pump in the reservoir. Fill reservoir with oil and prime the pump.

To prime the pump, connect the air supply line to the air inlet. Depress the PUMP end of the pedal and hold down the release valve with a common screwdriver. Allow the pump to cycle 15-20 times. Remove the screwdriver and depress the PUMP end of the pedal. If pressure builds, the pump has primed; if not, repeat this step until it does build pressure.

**3-3. CLEANING**

Wash the exterior of the bead breaker and pump with warm, soapy water. Rinse with

**CAUTION**



**3-4. STORAGE**

Anytime the tool is put away, a number of checks must be made:

Completely retract both rods. An exposed rod may be subject to rusting, pitting and damage from striking other tools.

If chloride is spilled on the tool, rinse with clean water and blow dry.

Nicks and dents in the rod surfaces should be carefully dressed with fine grit emory paper. If left unattended, they provide a starting point for rust.

NOTE

The chrome plated rod surfaces provide the seal for the tool. Any steps taken to ensure the continuing quality of the rod surfaces will increase the service life of the tool.

**3-5. TROUBLESHOOTING**

Table 1 lists problems, probable causes and solutions of the bead breaker and pump. Refer to Figures 5 and 6 for item numbers.

**TABLE 1. TROUBLESHOOTING CHART**

SYMPTOMS	PROBABLE CAUSE
Rods extend too slowly	Insufficient hydraulic pressure from pump 1. Check air supply (5-10 CFM at 100 PSI) 2. Check clearance of inlet check ball (item 9, Figure 6). Ball must be flush with or below end of filter adapter.
Rods fail to retract	Hydraulic pump doesn't release 1. Dirt under pump pedal in release valve area clean.  Bearing is misaligned on breaker rod (item 41, Figure 5) - correct or replace.  Broken or weak springs (item 7 or 35) replace.
Both rods extend at the same time.	Hydraulic pressure in breaker cylinder increases before clamping rod is fully extended. 1. Sequence ball (item 32, Figure 5) not seated or broken or weak spring (item 31, Figure 5) correct or replace. 2. Loose screw (item 9, Figure 5) and ball not seated (item 10, Figure 5) correct or replace.
Breaker rod retracts after clamping rod.	Hydraulic pressure in breaker cylinder is not being released. 1. Fluid return ball (item 11, Figure 5) didn't unseat correct or replace. 2. Dirt plug in return port clean.  Weak or broken spring in breaker cylinder replace.
Pump does not reciprocate.	Air piston stuck 1. Check cylinder bore of pump (item 60, Figure 6) for contamination or lack of lubrication. 2. Piston poppet (item 31, Figure 6) not sealing - replace.
Pump reciprocates ram will not extend.	Check prime 1. Depress both air valve and hydraulic release valve at the same time.
Pump extends ram but will not hold - system pressure leaks off.	1. Outlet check ball (item 6, Figure 6) not sealing properly correct or replace. 2. Release valve mechanism not sealing properly. Check pin (item 54, Figure 6), ball (item 50), release poppet (item 49) and poppet retainer (item 48) correct or replace.
Pump extends ram, but will not build to maximum pressure no visible signs of leakage.	1. Check air supply - 5-10 CFM at 100 PSI. 2. Check for internal leakage. A. Release valve mechanism. B. Low relief valve setting (item 7, Figure 6). C. Inlet check ball (item 9, Figure 6) not seating properly - correct or replace.
Pump extends ram but will not build to maximum pressure visible sign of leakage through air exhaust muffler.	1. Check piston subassembly. A. Replace washer, copper (item 14, Figure 6) and assemble in vertical position B. Replace gasket (item 16, Figure 6).



# Section 4

## Parts

### 4-1. INTRODUCTION

This section contains the parts drawings and lists for the IMT 200H series B bead breaker and the Air/Hydraulic pump. It also lists the conversion kits used to convert the series A bead breaker to the series B

### 4-2. CONVERSION KITS

Due to the fact that the parts for the IMT 200H series A bead breaker are no longer available, conversion kits have been made available. The differences between the series A and series B models are listed in Table 2. Table 3 lists the components that make up the internal conversion kit (part number 7Y000001) and the components it replaces. Table 4 lists the components comprising the external jaw conversion kit (part number 7Y000002) and the components it replaces. Numbers in parenthesis ( ) indicate quantities other than 1

TABLE 2. REVISIONS

Item No.	Part Number		Description
	Series A	Series B	
22	7Y060533 (2)	72060753 (2)	Socket Head Screw
23	(0)	7Y204238 (2)	Spacer
24	7Y036865 (2)	7Y043101	Jaw
25	7Y060568 (2)	7Y015985	Cup Point Screw
26	7Y060908 (2)	7Y018627	Cone Point Screw
39	7Y036863	7Y038052	Breaker Rod
40	(0)	7Y204237	Retaining Ring
41	7Y202639	7Y204236	Bearing
42	7Y016723 (2)	7Y201433	Retaining Ring
*	7Y202886	(0)	Bearing Retaining Pin
*	7Y202641	(0)	Spacer
*	7Y202633	(0)	Pin

\* Not shown - no Series B counterpart

TABLE 3. INTERNAL CONVERSION KIT (Part Number 7Y 000001)

Item No.	Part Number		Description
	Series A	Series B	
39	7Y036863	7Y038052	Breaker Rod
40	(0)	7Y204237	Retaining Ring
41	7Y202639	7Y204236	Bearing
42	7Y016723 (2)	7Y201433	Retaining Ring
*	7Y202886	(0)	Bearing Retaining Pin

\* Not shown - no Series B counterpart

TABLE 4. JAW CONVERSION KIT (Part Number 7Y000002)

Item No.	Part Number		Description
	Series A	Series B	
22	7Y060533 (2)	72060753 (2)	Socket Head Screw
23	(0)	7Y204238 (2)	
24	7Y036865 (2)	7Y043101	Jaw
25	7Y060568 (2)	7Y015985	Cup Point Set Screw
26	7Y060908 (2)	7Y018627	Cone Point Set Screw
*	7Y202641	(0)	Spacer
*	7Y202633	(0)	Pin

\* Not Shown - no Series B counterpart

4-3. INTERMEDIATE SERIES B

Some of the earlier single-finger jaw designs used a jaw illustrated on the left in Figure 4. That version is no longer available and has been replaced by the parts shown on the right in Figure 4. The part number for the jaw conversion kit is the same as the one in Table 4.

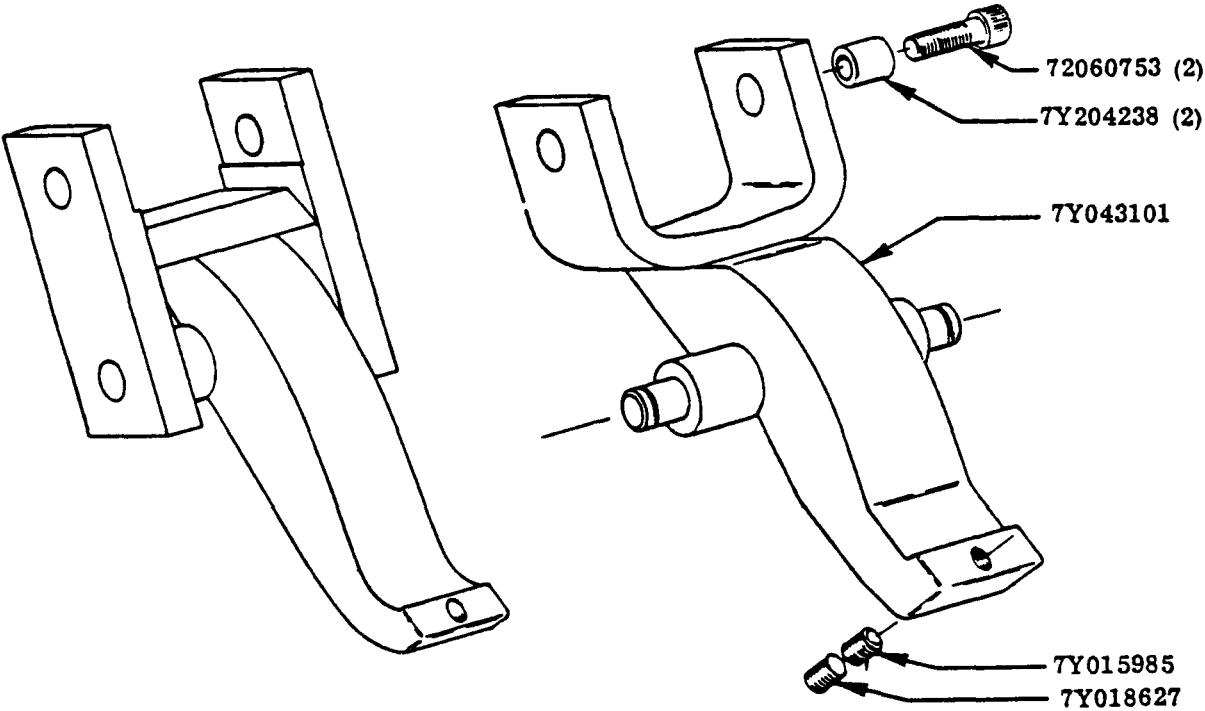

Figure 4. Jaw Conversion

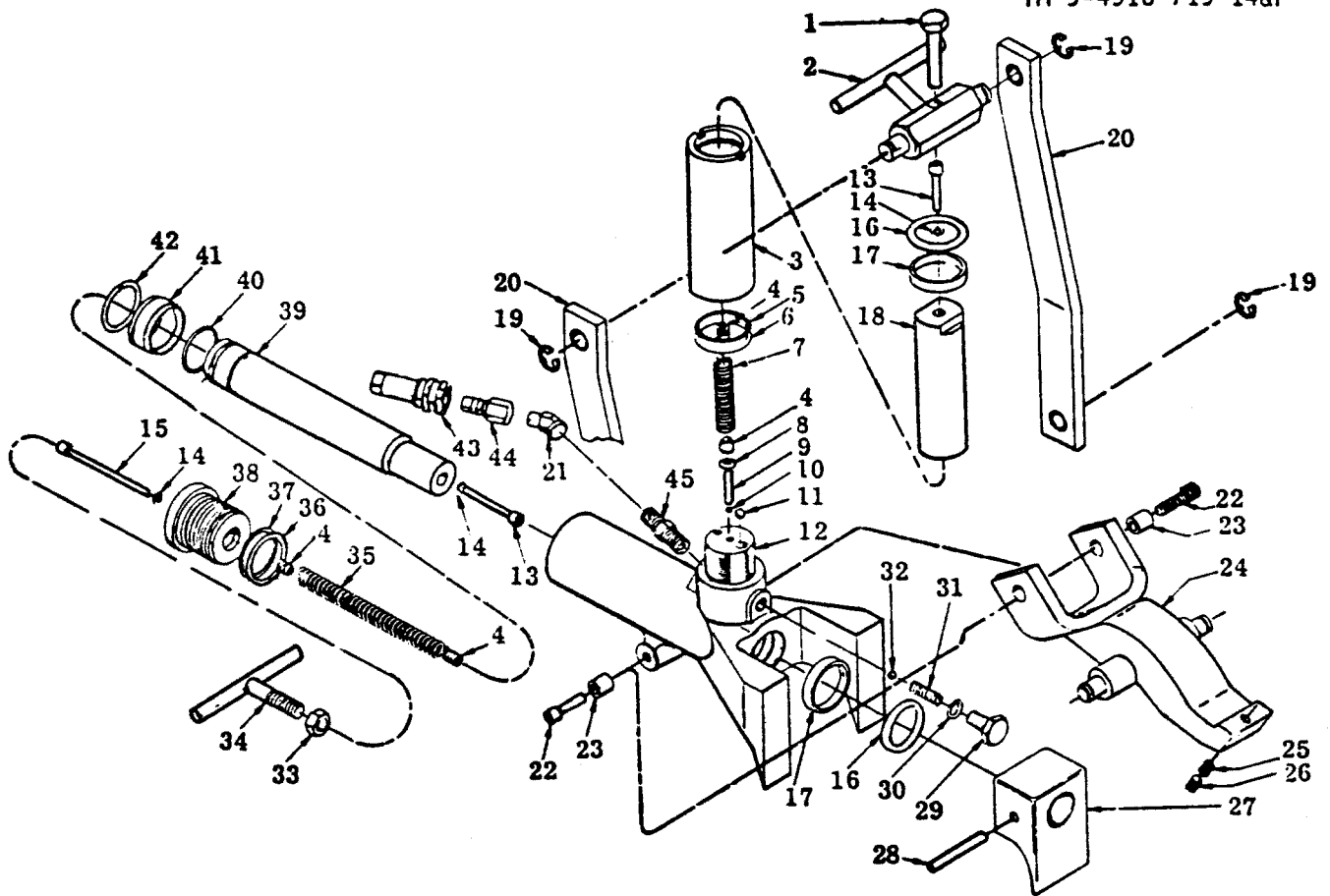

Figure 5. Bead Breaker Parts Drawing

Item No.	Part No.	Description	Qty	Item No.	Part No.	Description	Qty
1.	72060066	BOLT; 7/16-14 x 2" cap screw	1	24.	7Y043101	JAW, clamp 1	1
2.	7Y036949	BLOCK, handle	1	25.	7Y015985	SCREW; 3/8-16 x 1/2" soc set	1
3.	7Y036861	CYLINDER, clamp	1	26.	7Y018627	SCREW; 3/8-16 x 3/8" soc set	1
4.	7Y201360	ANCHOR, spring	4	27.	7Y036853	TONGUE, breaker	1
5.	7Q072220	O RING; 1-5/8 x 1-3/8"	1	28.	72066319	PIN, spring; 3/8 x 2-1/4"	1
6.	7Q10P220	WASHER, back-up	1	29.	ZY021599	CAP, valve spring	1
7.	7Y201430	SPRING	1	30.	7Y010261	WASHER	1
8.	7Y017160	WASHER	1	31.	7Y016724	SPRING	1
9.	72060562	SCREW; 1/4-20 x 1" soc. set	1	32.	72066437	BALL; 1/4 dia.	1
10.	72066435	BALL; 3/16 dia.	1	33.	72062024	NUT; 1/2-13	1
11.	72066439	BALL; 5/16 dia.	1	34.	7Y202636	HANDLE	1
12.	7Y050971	BODY	1	35.	7Y202625	SPRING	1
13.	72060708	SCREW; 1/4-20 x 1-1/4" soc. hd.	2	36.	7Q072224	O RING; 2" x 1-3/4	1
14.	7Y010442	WASHER, COPPER	3	37.	7Q10P224	WASHER, back-up	1
15.	72060907	SCREW; 1/4-20 x 3-1/2" soc hd.	1	38.	7Y036864	HEAD, breaker cylinder	1
16.	7R13P015	WIPER, rod	2	39.	7Y038052	ROD, breaker	1
17.	7R535015	U CUP	2	40.	7Y 204237	RING, retaining	1
18.	7Y036862	ROD, clamp	1	41.	7Y204236	BEARING	1
19.	7Y011901	RING, retaining, E	4	42.	7Y201433	RING, retaining	1
20.	7Y036866	ARM, clamp actuating	2	43.	7Y032285	COUPLER, female, quick disconnect	1
21.	72053533	ELBOW, street, 45°; 1/4 npt	1	44.	7Y032286	COUPLER, male, quick disconnect	1
22.	72060753	SCREW; 3/8-16 x 1" soc. hd.	1	45.	720535 17	NIPPLE, 1/4" npt	1
23.	7Y204238	SPACER	2				



ITEM NO.	PART NO.	DESCRIPTION	QTY	ITEM NO.	PART NO.	DESCRIPTION	QTY
1.	70141439	BODY, CHECK VALVE	1	41.	76391349	*GASKET	1
2.	7Q072218	*O RING	1	42.	76391347	MUFFLER	1
3.	72060645	SCREW, SOCKET HEAD: 1/4-20 UNC X 3/8" LG	1	43.	76391348	*GASKET	1
4.	70024221	*WASHER, COPPER	1	44.	70141428	BUTTON, RELEASE VALVE	1
5.	70141141	*SPRING, COMPRESSION	1	45.	7Q072010	*O RING	1
6.	70141095	*BALL, STEEL; 9/32" DIA.	1	46.	70141437	*SPRING, COMPRESSION	1
7.	73054282	RELIEF VALVE ASSY	1	47.	7Q092010	*O RING, DISOGRIN	2
8.	70141438	BODY, PUMP	1	48.	70141284	RETAINER, POPPET	1
9.	70141077	*BALL, STEEL; 1/4" DIA.	1	49.	70141285	POPPET, RELEASE VALVE	1
10.	70024222	*WASHER, COPPER	1	50.	70141287	BALL, STEEL; 3/32" DIA.	1
11.	70141436	ADAPTER, FILTER	1	51.	70141600	RETAINER, BALL	1
12.	70048023	FILTER	1	52.	70141427	*SPRING, COMPRESSION	1
13.	70141136	PISTON	1	53.	76391350	*O RING, DISOGRIN	1
14.	70024215	*WASHER, COPPER	1	54.	70141085	PIN, DOWEL	1
15.	70141440	CYLINDER	1	55.	76391171	*GASKET, RESERVOIR	1
16.	76391214	*GASKET	1	56.	70141426	WASHER, WAVY	2
17.	70141429	NUT, RETAINER	1	57.	70141425	RESERVOIR	1
18.	72066021	RING, RETAINING	1	58.	76391346	SEAL	1
19.	76391235	PACKING, U CUP, NYLON	1	59.	76391345	*RING, BACK-UP	1
20.	70141441	SPRING, COMPRESSION	1	60.	70141424	CYLINDER, AIR	1
21.	70141137	GUIDE, SPRING	1	61.	72060639	SCREW, SOCKET HD. CAP; 10-24 X1-1/4" LG.	6
22.	70141442	SPRING	1	62.	70141286	PLUG, FILLER	1
23.	7Q072018	*O RING	1	63.	70141423	PLATE, COVER	1
24.	70029164	BODY, PISTON	1	64.	70141422	PIN	1
25.	70141283	*RING, PISTON	2	65.	72066556	RING, RETAINING, E TYPE	2
26.	76391344	*GASKET	1	66.	70141288	BODY, RELEASE VALVE	1
27.	70141431	HEAD, REAR	1	67.	73029148	PEDAL	1
28.	72063047	LOCK WASHER; #10	3	68.	70141086	BODY, INTAKE AIR VALVE	1
29.	72060552	SCREW, SOCKET HD. CAP; 10-24 X 1/2"	3	69.	70141290	SCREW, THREAD FORMING	6
30.	70141432	PLATE, PISTON END	1	70.	72060727	SCREW, SOCKET HD. CAP; 1/4-20 X 4" LG.	4
31.	76039495	*POPPET, PISTON	1	71.	72063049	LOCK WASHER	4
32.	70141269	STEM, EXHAUST VALVE	1	72.	70141421	TUBE, FOAM	1
33.	7Q072139	*O RING	2	73.	72532138	BUSHING, REDUCING, 3/8" X 1/4" NPT	1
34.	70141435	*SPRING	1	74.	51073049	HOSE	1
35.	7Q072210	*O RING	2				
36.	72060539	SCREW, SOCKET HD. CAP; 8-32 X 1/4"	1				
37.	70141434	GUIDE, SEAL	1				
38.	70141291	*POPPET, AIR VALVE	1				
39.	7Q072011	*O RING	1				
40.	70141433	BUTTON, ACTUATOR	1				
						*PART OF REPAIR KIT (PART NUMBER 76039496)	

## Section 5 Oil Specifications

Table 5. Hydraulic Oil Specifications

Ambient temperature range	0-90	Below 32	32-90	Above 90
Min. Pour Point, ° F	-30	-25 +	+10	+10
Max. Viscosity, SSU @ 0° F	4000	4000		
Min. Viscosity, SSU @ 100° F	140-195	100-130	150-200	200-315
Min. Viscosity, SSU @ 210° F	48	41 43	43	47
Min. Viscosity Index	139	90	90	90

**OIL SELECTION:** Minimum viscosity specifications for hydraulic oil to be used in the IMT 200 HP System are given in table 5. Any major oil company can supply products which meet these requirements.

Oils selected by user for this class of equipment, in addition to meeting viscosity requirements, should have the following additives:

1. Antifoam inhibitors
2. Antioxidant inhibitors
3. Rust resistant additives
4. Antiwear additives

**OIL SPECIFICATIONS:** Table 5 provides oil specifications for a full range of operating temperatures encountered in the temperate zones. Arctic conditions present special requirements which are not within the scope of the table and must be given special consideration and individual analysis. Consult your oil supplier for the proper fluid for working under these severe conditions.

Contamination of the hydraulic oil by solvents, water, dust or other abrasives will result in a premature breakdown of the oil's anti foam, lubrication, anti-rust and viscosity prop-

erties. Prolonged exposure to water or high operating temperatures (above 180°F) will cause an increase in the oxidation rate, producing varnish forming materials and sludge in the oil.

Periodically a sample of the hydraulic oil in the system should be drawn off and its condition checked for breakdown. To check oil quality:

1. Place oil sample in a clean glass.
2. Smell oil to detect a burnt or rancid odor.
3. Examine the oil for a cloudy or dark color.
4. Allow the sample to stand for several minutes and inspect it for water which will settle to the bottom. Water can result from a leak in the system or condensation due to temperature extremes.

When any of these conditions is observed, the system should be purged and filled with new oil.

In addition, the oil should be changed in the reservoir and complete system after 800 hours of operation (or every six months which ever occurs first) and after pump or other major hydraulic component failure.

**By Order of the Secretary of the Army:**

**E. C. MEYER**  
*General, United States Army*  
*Chief of Staff*

**Official:**

**ROBERT M. JOYCE**  
*Brigadier General, United States Army*  
*The Adjutant General*

☆ U.S. GOVERNMENT PRINTING OFFICE : 1990 O - 261-872/21141.





RECOMMENDED CHANGES TO EQUIPMENT TECHNICAL PUBLICATIONS



THEN... JOT DOWN THE DOPE ABOUT IT ON THIS FORM. CAREFULLY TEAR IT OUT. FOLD IT AND DROP IT IN THE MAIL!

SOMETHING WRONG WITH THIS PUBLICATION?

FROM: (PRINT YOUR UNIT'S COMPLETE ADDRESS)

Your mailing address

DATE SENT

Date you filled out form.

PUBLICATION NUMBER

TM 9-XXXX-XXX-XX

PUBLICATION DATE

Date of TM

PUBLICATION TITLE

Title of TM

BE EXACT... PIN-POINT WHERE IT IS

IN THIS SPACE TELL WHAT IS WRONG AND WHAT SHOULD BE DONE ABOUT IT:

PAGE NO	PARA. GRAPH	FIGURE NO	TABLE NO
400		183	
512		191	

Change illustration Reason: Tube end shown assembled on wrong side of lever cam.

Figure 191, item 3 has the wrong NSN. Supply rejects orders for this item. The NSN shown here is not listed in the AMDF or the MCRL.

Please give us the correct NSN and P/N.

SAMPLE

PRINTED NAME, GRADE OR TITLE, AND TELEPHONE NUMBER

John Smith, S. SGT. 793/XXXX

SIGN HERE

*John Smith*

TEAR ALONG PERFORATED LINE

FILL IN YOUR  
UNIT'S ADDRESS

FOLD BACK

DEPARTMENT OF THE ARMY

POSTAGE AND FEES PAID  
DEPARTMENT OF THE ARMY  
DOD 314



TEAR ALONG PERFORATED LINE

OFFICIAL BUSINESS  
PENALTY FOR PRIVATE USE \$300

Commander  
US Army Armament Materiel Readiness Command  
ATTN: DRSAR-MAS  
Rock Island, IL 61299

RECOMMENDED CHANGES TO EQUIPMENT TECHNICAL PUBLICATIONS



THEN... JOT DOWN THE DOPE ABOUT IT ON THIS FORM. CAREFULLY TEAR IT OUT, FOLD IT AND DROP IT IN THE MAIL!

**SOMETHING WRONG WITH THIS PUBLICATION?**

FROM: (PRINT YOUR UNIT'S COMPLETE ADDRESS)

DATE SENT

PUBLICATION NUMBER

TM 9-4910-719-14&P

PUBLICATION DATE

25 Jan 82

PUBLICATION TITLE

Bead Breaker,  
Pneumatic Model IMT 200 HP

BE EXACT. PIN-POINT WHERE IT IS

PAGE NO.

PARA-GRAPH

FIGURE NO.

TABLE NO.

IN THIS SPACE TELL WHAT IS WRONG AND WHAT SHOULD BE DONE ABOUT IT:

TEAR ALONG PERFORATED LINE

PRINTED NAME, GRADE OR TITLE, AND TELEPHONE NUMBER

SIGN HERE:

FILL IN YOUR  
UNIT'S ADDRESS

FOLD BACK

DEPARTMENT OF THE ARMY

POSTAGE AND FEES PAID  
DEPARTMENT OF THE ARMY  
DOD 314



OFFICIAL BUSINESS  
PENALTY FOR PRIVATE USE \$300

Commander  
US Army Armament Materiel Readiness Command  
ATTN: DRSAR-MAS  
Rock Island, IL 61299

TEAR ALONG SEPARATED LINE

RECOMMENDED CHANGES TO EQUIPMENT TECHNICAL PUBLICATIONS



THEN... JOT DOWN THE DOPE ABOUT IT ON THIS FORM, CAREFULLY TEAR IT OUT, FOLD IT AND DROP IT IN THE MAIL!

**SOMETHING WRONG WITH THIS PUBLICATION?**

FROM: (PRINT YOUR UNIT'S COMPLETE ADDRESS)

DATE SENT

PUBLICATION NUMBER  
TM 9-4910-719-14&P

PUBLICATION DATE  
25 Jan 82

PUBLICATION TITLE  
Bead Breaker,  
Pneumatic Model IMT200HP

BE EXACT... PIN-POINT WHERE IT IS

IN THIS SPACE TELL WHAT IS WRONG AND WHAT SHOULD BE DONE ABOUT IT:

PAGE NO.	PARA-GRAPH	FIGURE NO.	TABLE NO.
----------	------------	------------	-----------

TEAR ALONG PERFORATED LINE

PRINTED NAME, GRADE OR TITLE, AND TELEPHONE NUMBER

SIGN HERE:

FILL IN YOUR  
UNIT'S ADDRESS

FOLD BACK

DEPARTMENT OF THE ARMY

POSTAGE AND FEES PAID  
DEPARTMENT OF THE ARMY  
DOD 314



OFFICIAL BUSINESS  
PENALTY FOR PRIVATE USE \$300

Commander  
US Army Armament Materiel Readiness Command  
ATTN: DRSAR-MAS  
Rock Island, IL 61299

TEAR ALONG SEPARATED LINE

RECOMMENDED CHANGES TO EQUIPMENT TECHNICAL PUBLICATIONS



THEN... JOT DOWN THE DOPE ABOUT IT ON THIS FORM. CAREFULLY TEAR IT OUT. FOLD IT AND DROP IT IN THE MAIL!

**SOMETHING WRONG WITH THIS PUBLICATION?**

FROM: (PRINT YOUR UNIT'S COMPLETE ADDRESS)

DATE SENT

PUBLICATION NUMBER

TM 9-4910-719-14&P

PUBLICATION DATE

25 Jan 82

PUBLICATION TITLE *Bead Breaker,*  
Pneumatic Model IMT 200 HP

BE EXACT. PIN-POINT WHERE IT IS

PAGE NO.	PARA-GRAPH	FIGURE NO.	TABLE NO.
----------	------------	------------	-----------

IN THIS SPACE TELL WHAT IS WRONG AND WHAT SHOULD BE DONE ABOUT IT:

TEAR ALONG DASHED LINE

PRINTED NAME, GRADE OR TITLE, AND TELEPHONE NUMBER

SIGN HERE:

FILL IN YOUR  
UNIT'S ADDRESS

FOLD BACK

DEPARTMENT OF THE ARMY

POSTAGE AND FEES PAID  
DEPARTMENT OF THE ARMY  
DOD 314



OFFICIAL BUSINESS  
PENALTY FOR PRIVATE USE \$300

Commander  
US Army Armament Materiel Readiness Command  
ATTN: DRSAR-MAS  
Rock Island, IL 61299

TEAR ALONG PERFORATED LINE





**TM 9-4910-719-14&P BEAD BREAKER, PNEUMATIC MODEL IMT 200HP-1982**

**PIN : 050549-000.**